

ELECTRICAL FEATURES

| | |
|---------------------|------------------------|
| INPUT VOLTAGE | 220 - 240V Ac, 50-60HZ |
| INPUT CURRENT | 0.22A |
| POWER RATE | 50W |
| DIMMABILITY | NO |
| POWER FACTOR | 0.97 |
| OUTPUT VOLTAGE | 12V Ac, 50 - 60HZ |
| OUTPUT CURRENT | 4.16A |
| WORKING TEMPERATURE | ≤ 85° |
| NEMA /UL | CLASS B |

GENERAL FEATURES

Small Size | Low Mechanical Hum | Low Weight | Easy Mounting

1. Protections:

(a) Over voltage protected (OVP) | (b) Over Temperature Protection (OTP)

(c) In-rush Current Protection (ICP)

2D LAYOUT

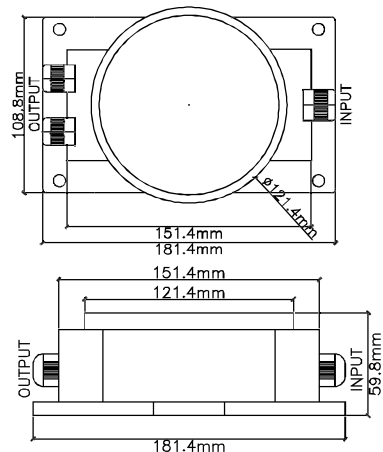

MECHANICAL FEATURES

| PAKING SIZE | WEIGHT | COIL WIRE | COIL STRAUTURE | CORE MATERIAL | BODY MATERIAL | INSULATION CLASS |
|-----------------|--------|-------------|----------------|-------------------|---------------|------------------|
| 230 x 150x 85mm | 2.1KG | Copper 100% | Toroidal | Siliconized Steel | ABS | CLASS B |



PRODUCT IMAGE

