

TREE MOUNTING STRAP ACCESSORIES



Product Features

Bracket Material	Brass
Strap Material	Rubber
Color Finish	Antique Brass
Size of trunk	Max Ø200mm



Strap Dimension

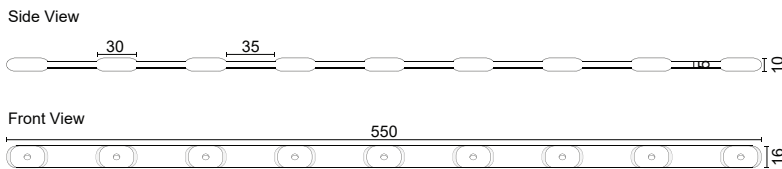

Bracket Dimension

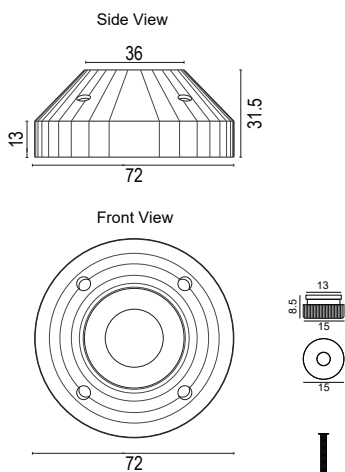

- This product can be used for trees with a max Ø200mm trunk.
- In order to use the strap for smaller size of trees you can cut the rubber belt to match the size of the trunk accordingly.
- Flexible Tree Strap Brass Mounting:
This accessory kit includes one/two rubber bungee straps and a sturdy brass mounting plate. The tree strap will accommodate any LUMO brass spot-light with a threaded knuckle.
The elastic strap(s) is an alternative to bulky fixture mounts and rings which require using screws to fix them to the tree. This fixture provides an easy-to-install mounting feature that can be adjusted during maintenance to prevent damage to the trunk of trees.
- Features:
 - Accommodates one fixture
 - No screws to be used or hardware to damage trunk of trees.
 - Flexible straps stretch in diameter overtime to allow for healthy tree growth.
 - Heavy-duty brass mounting plate made to withstand the outdoor elements.
 - Threaded opening in mounting plate fits all threaded LUMO fixtures.
 - Lifetime warranty on mount and one year warranty on straps



Project Name: Palm Dubai, UAE