

# TREE MOUNTING DOUBLE STRAP ACCESSORIES

## INSTALLATION INSTRUCTIONS



PART NO.	NO.OF LIGHT FIXTURES	MATERIAL
LUXXPACC-BRS22	1	Brass Bracket + Rubber Strap

### Strap

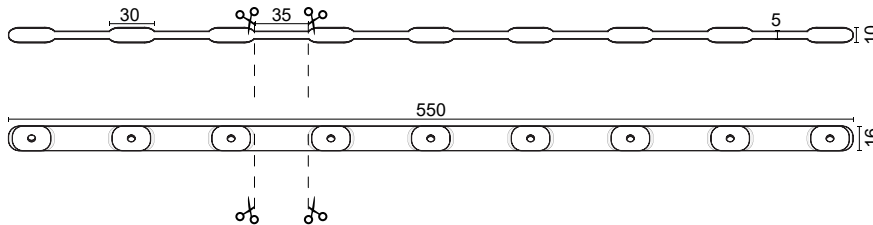

### Bracket

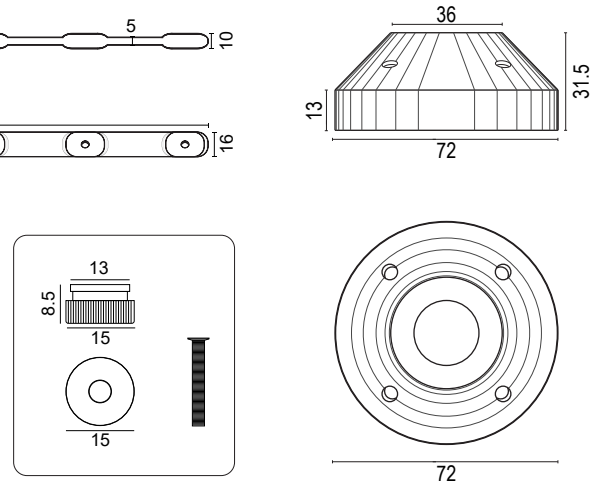

This product can be used for trees with a max Ø200mm trunk. In order to use the strap for smaller size of trees you can cut the rubber belt to match the size of the trunk accordingly.

1

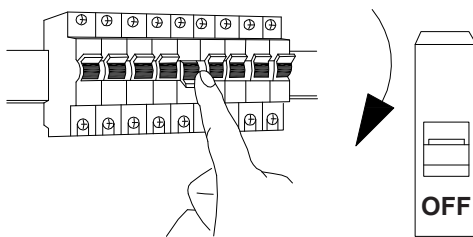

Turn off electrical power to all affected circuits before installation

2

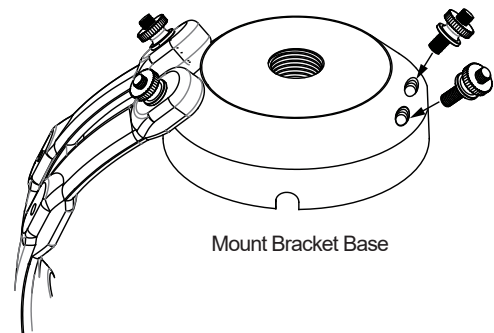

Fix the one bungee double strap to the brass bracket from one side.

x 4

x 4

x 2

**WARNINGS** All electrical works must be done by a qualified electrician.  
 Turn off electrical power to all affected circuits before installation or servicing.  
 For any technical support contact LUMO® experts in [info@lumo.ae](mailto:info@lumo.ae)

# TREE MOUNTING DOUBLE STRAP ACCESSORIES INSTALLATION INSTRUCTIONS

# LUMO®

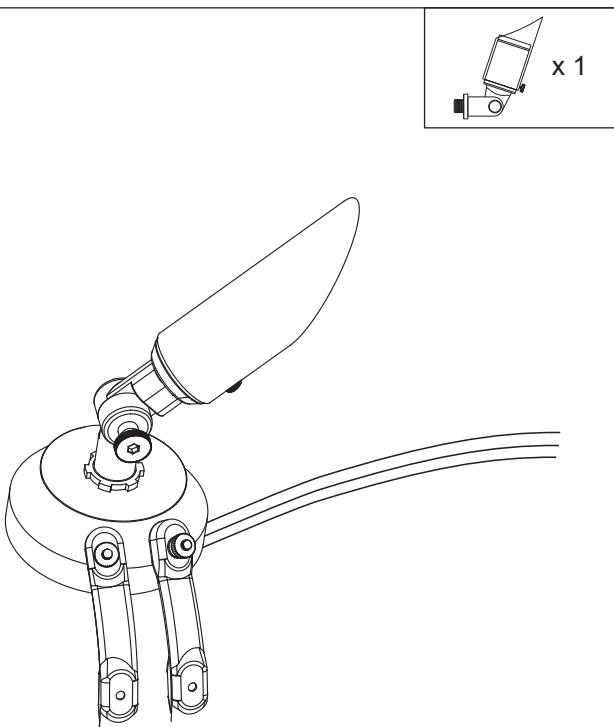
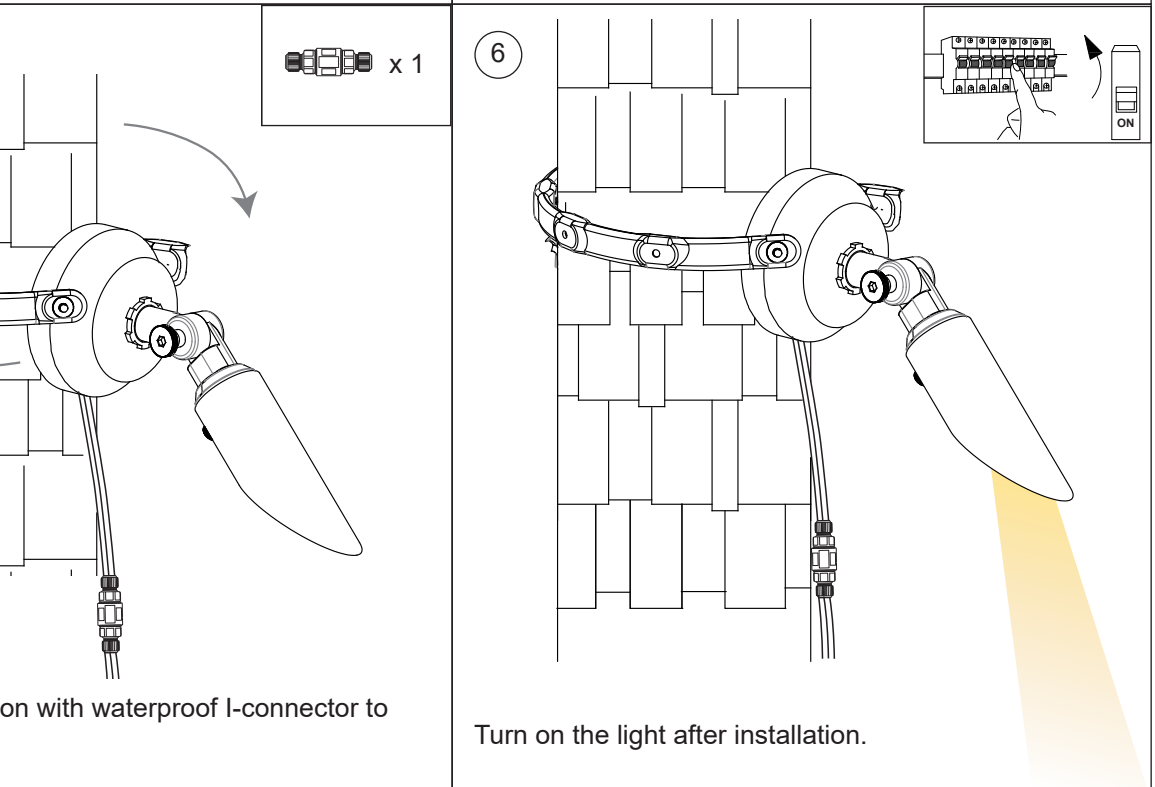
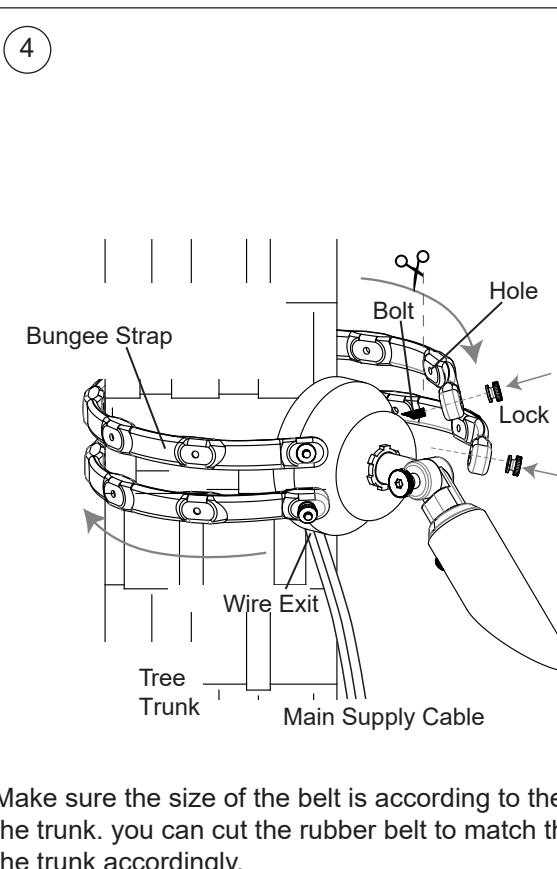
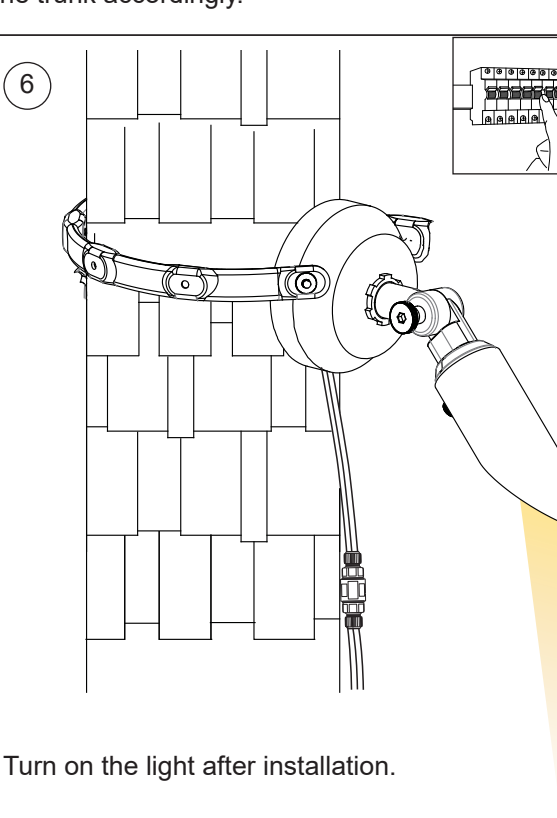
<p>3</p>  <p>Insert the light into the brass bracket and take out the wire into the bracket</p>	<p>4</p>  <p>Make sure the size of the belt is according to the size of the trunk. you can cut the rubber belt to match the size of the trunk accordingly.</p>
<p>5</p>  <p>Take cable connection with waterproof I-connector to 12V transformer.</p>	<p>6</p>  <p>Turn on the light after installation.</p>

**WARNINGS** All electrical works must be done by a qualified electrician.  
Turn off electrical power to all affected circuits before installation or servicing.  
For any technical support contact LUMO® experts in [info@lumo.ae](mailto:info@lumo.ae)