

LED RECESSED CURVED INGROUND LIGHT INSTALLATION INSTRUCTIONS

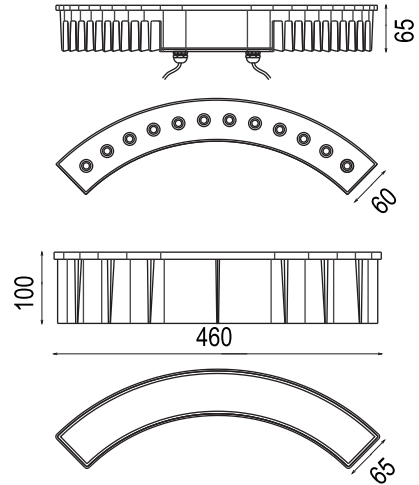

PART NAME	INPUT VOLTAGE	MATERIAL	IP RATING
LU012RCIG-CR01	24V DC	Aluminum + Tempered Glass	IP67

1 Component Overview & Dimension

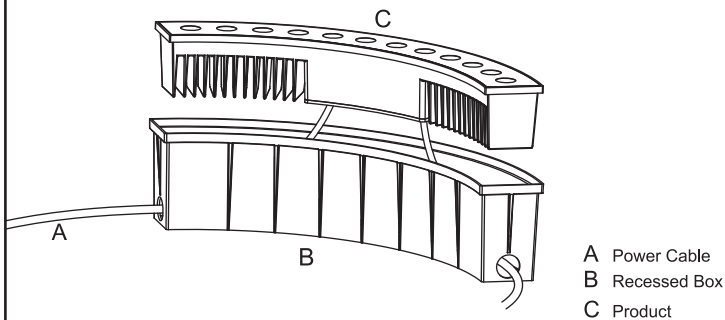

2 Recessed Box & Product

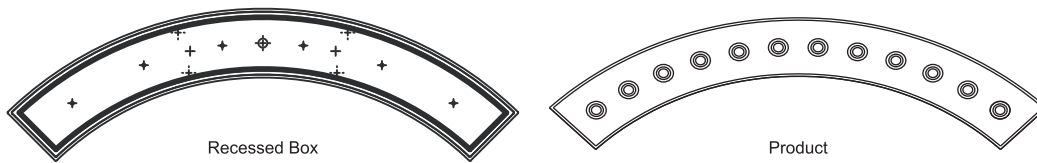

3 Installation Details

Side View

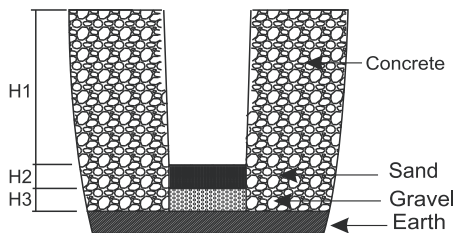

Top View

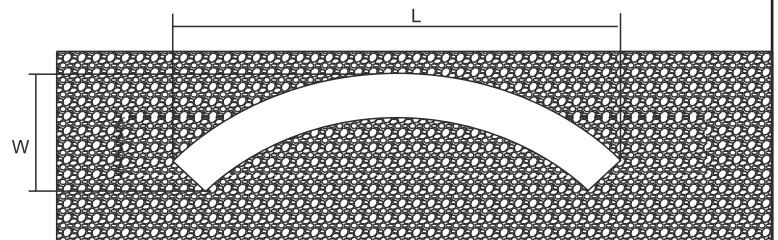

4 Install Recessed sleeve Box

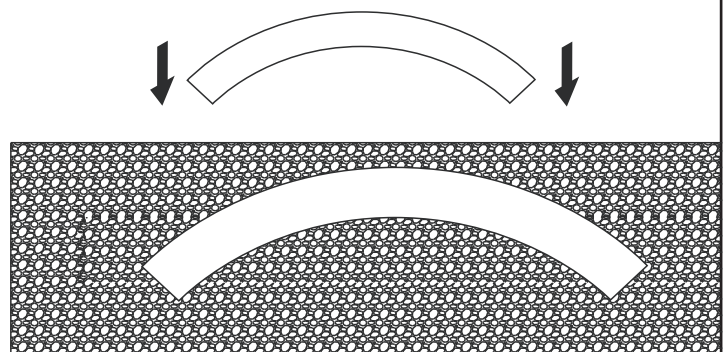
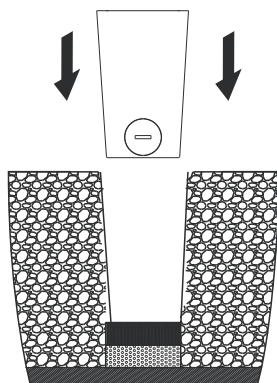

LED RECESSED CURVED INGROUND LIGHT INSTALLATION INSTRUCTIONS

LUMO®

④ Install LED Inground Light

Side View

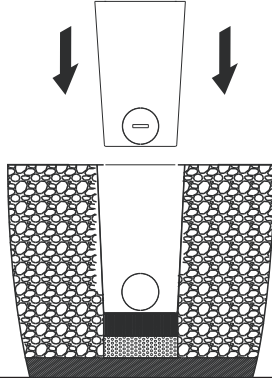

Top View

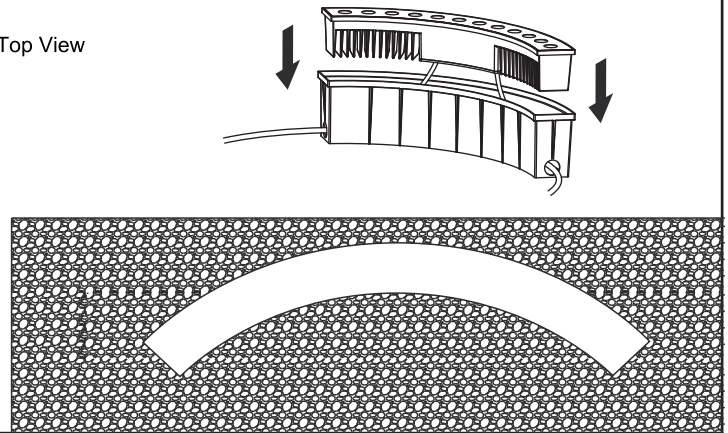

⑤ Schematic diagram of installation effect

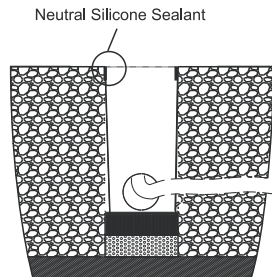

Neutral Silicone Sealant

Glue around the lamp and tighten the lamp
Note: Do not use the acidic glass glue and deoxime silicone adhesive

⑥ Cable connections

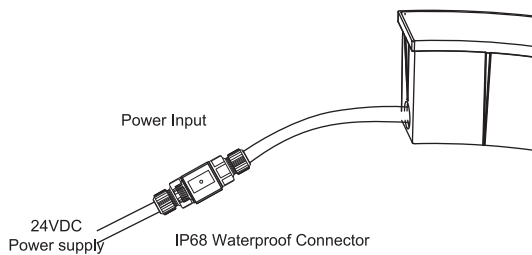

24VDC
Power supply

IP68 Waterproof Connector

Power Input

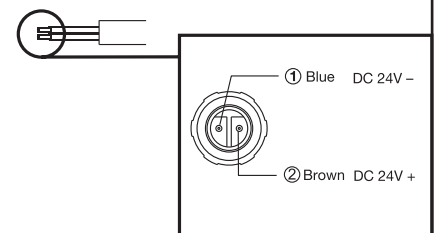

① Blue DC 24V -

② Brown DC 24V +

Note : This product is out of warranty if :

- 1-The installation method is not followed as per instruction-sheet
- 2-Installation material is not used properly
- 3-Waterproofing is not done as per instruction method
- 4-Waterproofing connectors are not used
- 5-The correct voltage is not used
- 6- If the light is permanently submerged in water
- 7- If drainage is not provided to drain the rain water

Note : To prevent any risk while doing installation of this product an electrical engineer need to install / supervise installation team.

WARNINGS

This light is a low voltage light so contact LUMO for a proper driver / Transformer to be used.
All electrical works must be done by a qualified electrician.
Turn off electrical power to all affected circuits before installation or servicing.
For any technical support contact LUMO® experts in info@lumo.ae