

MR16 LAMP BASED UNDERWATER LIGHT INSTALLATION INSTRUCTIONS

LUMO®

PART NO.	LAMP TYPE	DIMENSION	IP RATING
LUMR16UW-BR01	MR16	L115 x W100 x H119 mm	IP68

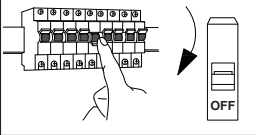

A. (2) Mounting Screw (not included)
 B. (2) Washers (not included)
 C. (2) Anchors (not included)
 D. (1) MR16 Lamp (sold separately)
 E. (1) Transformer (sold separately)

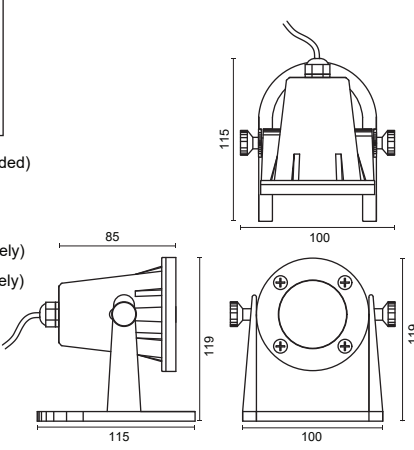

① Turn Off the power before starting installation.

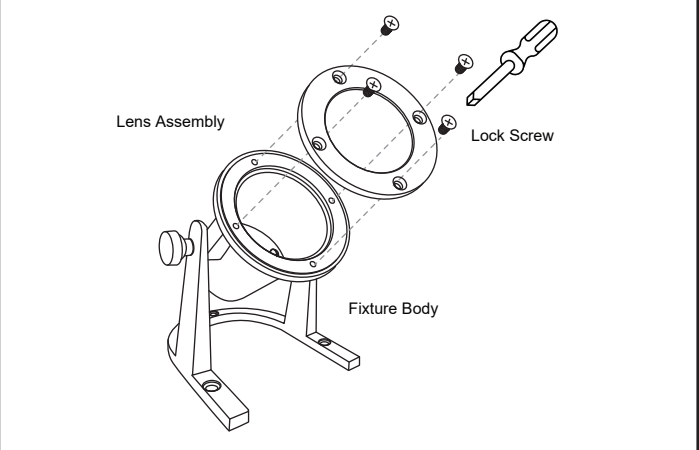

② Remove lens assembly - Using a screwdriver, loosen the lock screws and remove the lens assembly from the fixture body.

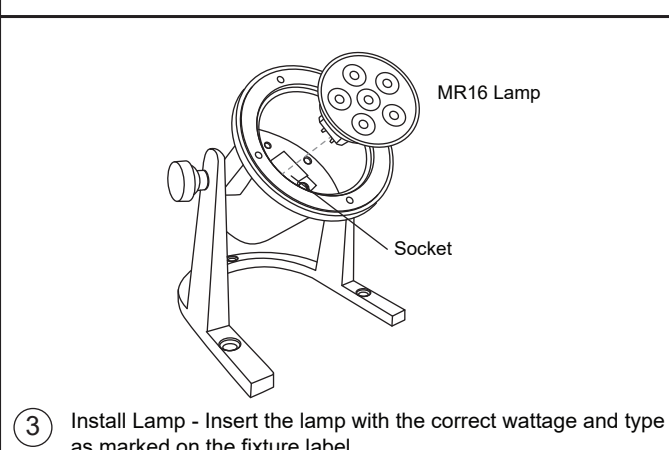

③ Install Lamp - Insert the lamp with the correct wattage and type as marked on the fixture label.

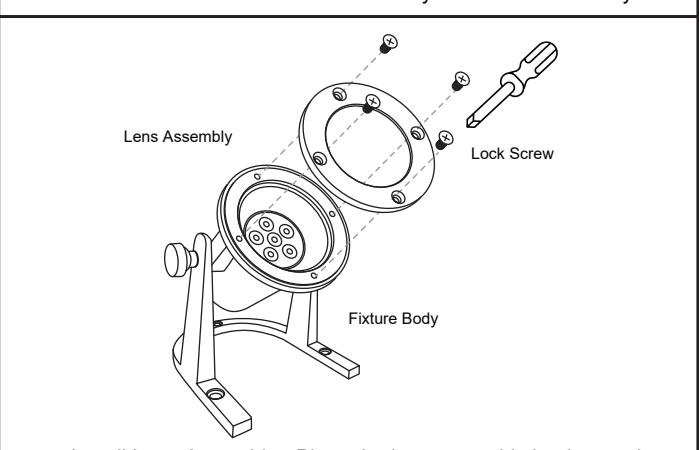

④ Install Lens Assembly - Place the lens assembly back onto the fixture body and secure with lock screws. Tighten until snug with a screwdriver.

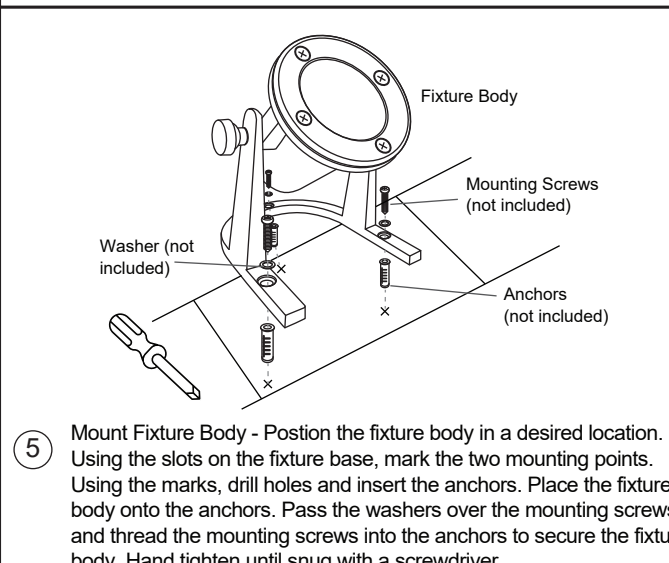

⑤ Mount Fixture Body - Position the fixture body in a desired location. Using the slots on the fixture base, mark the two mounting points. Using the marks, drill holes and insert the anchors. Place the fixture body onto the anchors. Pass the washers over the mounting screws and thread the mounting screws into the anchors to secure the fixture body. Hand tighten until snug with a screwdriver.

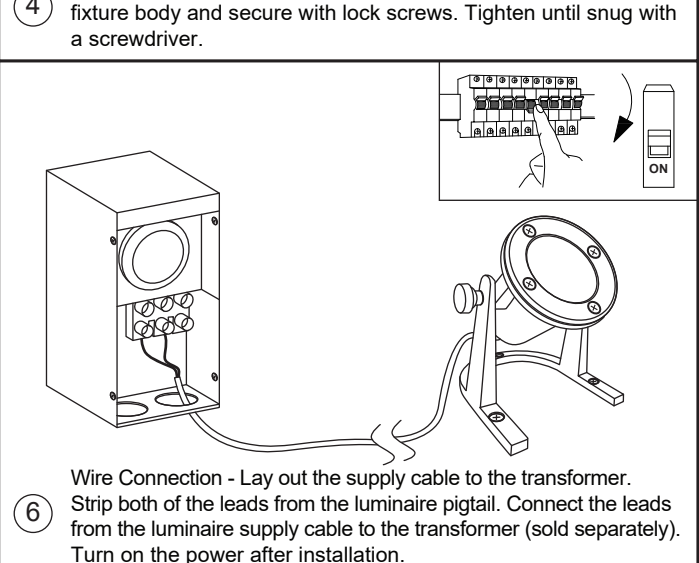

⑥ Wire Connection - Lay out the supply cable to the transformer. Strip both of the leads from the luminaire pigtail. Connect the leads from the luminaire supply cable to the transformer (sold separately). Turn on the power after installation.

WARNINGS All electrical works must be done by a qualified electrician.
 Turn off electrical power to all affected circuits before installation or servicing.
 For any technical support contact LUMO® experts in info@lumo.ae